

D

C

B

A

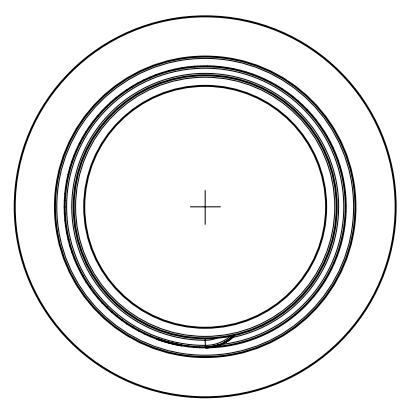

SCALE 0.750

REV	DATE	BY	REVISION
	082510	RRJ	THIS DRAWING WAS COPIED FROM DWG. GMP-1028-C-PD
A	091410	RRJ	REVISED TITLE BLOCK AND NOTES.
B	092710	RRJ	B1 WAS 4.092, B2 WAS .012 WALL.
C	101410	RRJ	C1 REMOVED NOTES 5 & 6, C2 CONTROLLED "C" WAS "I" DIM., C3 ADDED "I" MIN., C4 REMOVED 2.992, C5 REMOVED 1.590, C6 ADDED Ø1.370 REF.
D	102315	ES	REDRAWN FROM 3165-0203-C

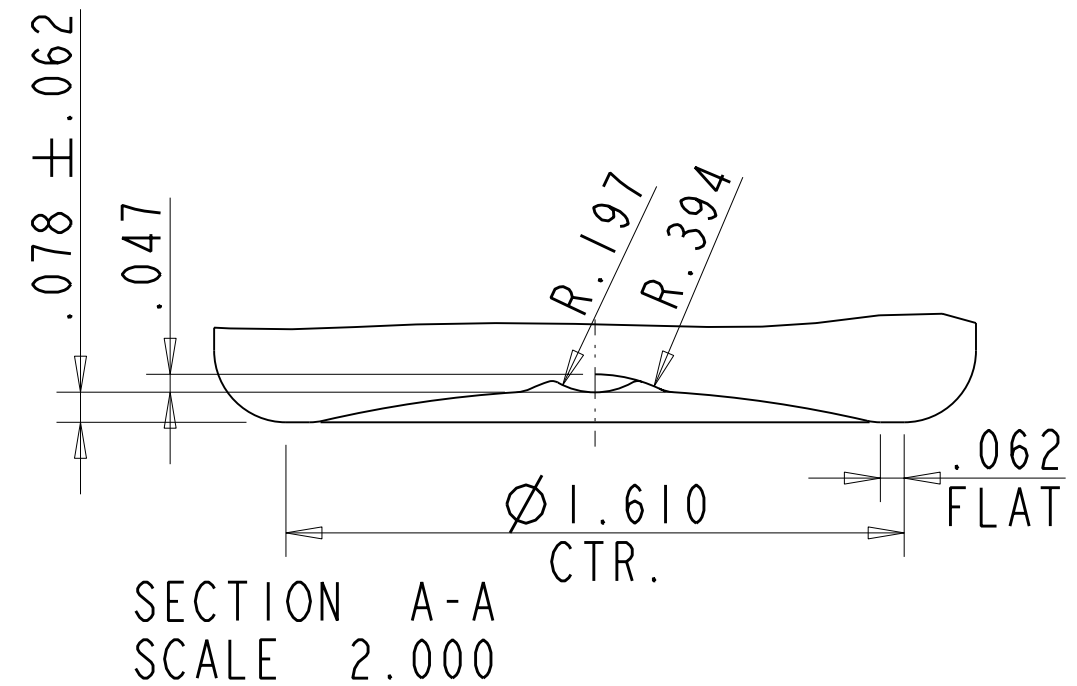
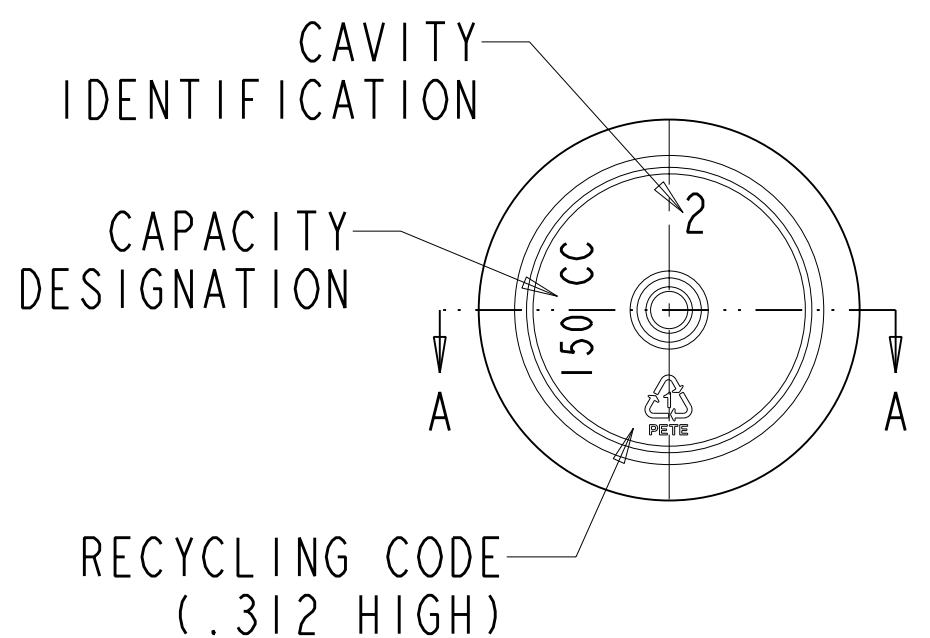
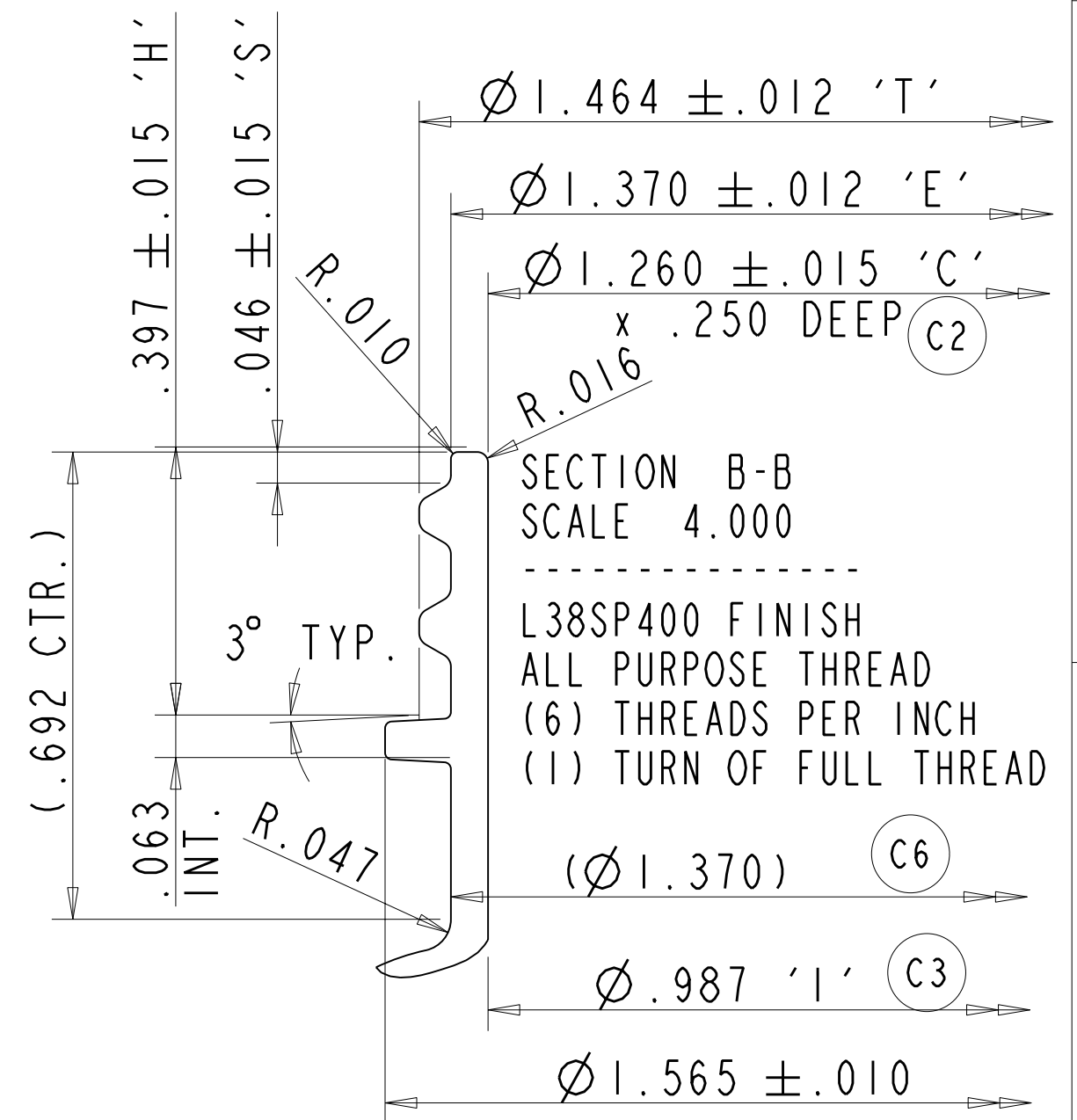
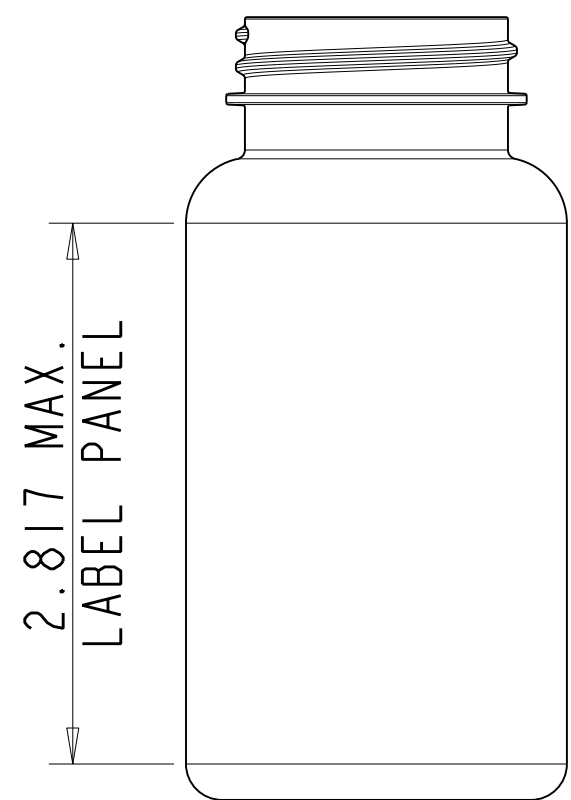
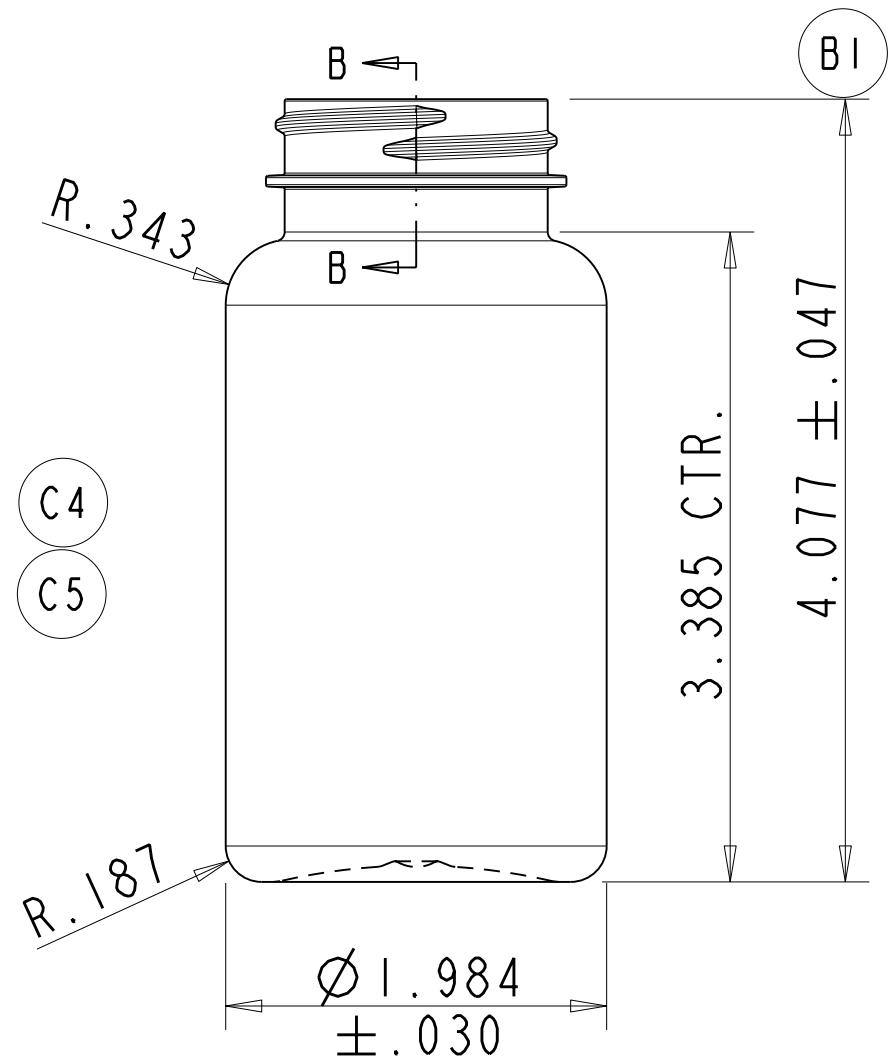

- (B2) NOTES:
- 1 - MOLD NO. NB-400113
 - 2 - MAX. VARIATION IN AVERAGE DIAMETER BETWEEN TOP AND BOTTOM NOT TO EXCEED .010
 - 3 - ALL DIMENSIONS APPLY AS MOLDED
 - 4 - MAXIMUM OUT OF ROUNDNESS ON BODY OF CONTAINER NOT TO EXCEED .015

RESTRICTED, CONFIDENTIAL DOCUMENT

THIS DOCUMENT AND THE INFORMATION THEREON IS THE SOLE AND EXCLUSIVE PROPERTY OF PERFORMANCE PLASTIC TECHNOLOGIES AND/OR ITS DESIGNATED DISTRIBUTOR ABOVE. IT IS BEING ENTRUSTED TO RECIPIENT FOR A SPECIFIC LIMITED PURPOSE AND MAY BE USED ONLY FOR SUCH PURPOSE. BY ACCEPTING THIS DOCUMENT, THE RECIPIENT AGREES THAT HE WILL ENSURE THAT THE DOCUMENT AND ALL INFORMATION THEREON: (1) WILL BE MAINTAINED IN STRICTEST CONFIDENCE; (2) WILL NOT BE REPRODUCED, IN WHOLE OR IN PART, IN ANY MANNER WHATSOEVER WITHOUT THE EXPRESS WRITTEN APPROVAL OF PPT; (3) WILL NOT BE DISCLOSED DIRECTLY OR INDIRECTLY, IN ANY MANNER OR FORM, TO ANY THIRD PARTY WITHOUT THE EXPRESS WRITTEN APPROVAL OF PPT AND; (4) WILL BE PROMPTLY AND VOLUNTARILY RETURNED, WITH ANY AND ALL COPIES, TO PPT WHEN IT HAS SERVED THE PURPOSE INTENDED BY PPT, OR AT THE REQUEST OF PPT.



150 cc CT ROUND WIDE MOUTH PACKER
L38SP400 FINISH

24.86 SQUARE INCHES	6.83 SQUARE INCHES	20.0 ±1.0	PET	170.0 ±5 cc (5.75 ±.17 fl oz)
SURFACE AREA BELOW BASE OF NECK	AREA AT PART LINE BELOW BASE OF NECK	GRAMS	MAT'L.	OVERFLOW CAPACITY

FILE NAME: XXXX_150cc-STR-SIDE (15-077-01-D)	SIZE C	DRAWN BY: RRJ	DWG NO. 3165-0203-D
SCALE: 1,4:1	DATE: 08-25-2010	SHEET	1 OF 1

1

2

3

4