

REV	DATE	BY	REVISION
A	102115	ES	REDRAWN FROM GMP-1014-C-PD TO MATCH CURRENT DRAWING SERIES FORMAT- INTERIM REVISIONS NOT KNOWN, REVISED TITLE BLOCK, A1 MODIFIED NOTES, A2 REMOVED DIM'S 2.992 & 1.590, A3 REVISED THREAD DETAIL.
B	051017	ES	UPDATED PUSHUP ENGRAVING, ADDED VIEW WITH ALTERNATE ENGRAVING.
C	081518	ES	ADDED MIN. WALL LOCATION & NOTE 5.

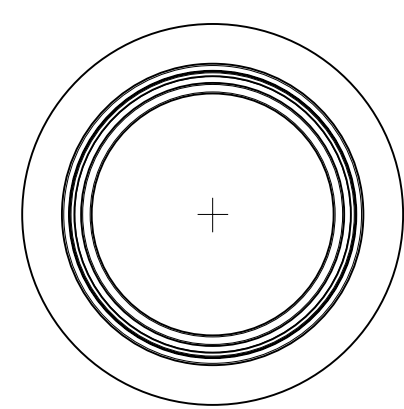

SCALE 0.750

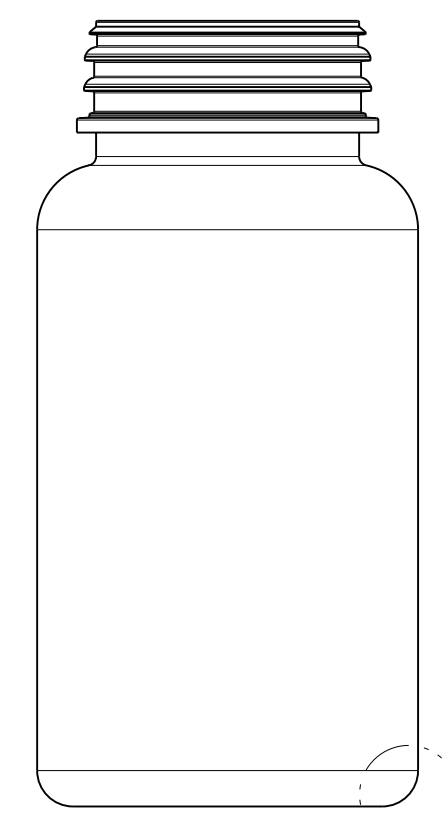
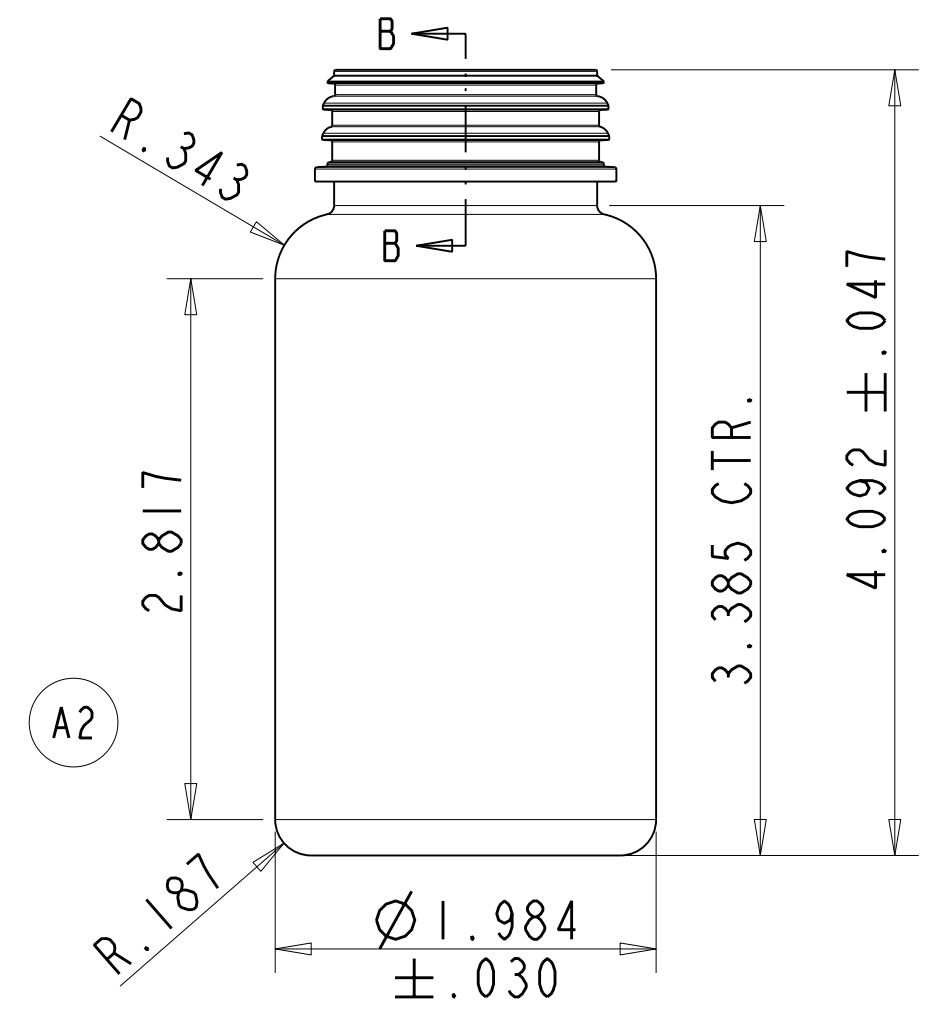

Ø .012" MIN. WALL

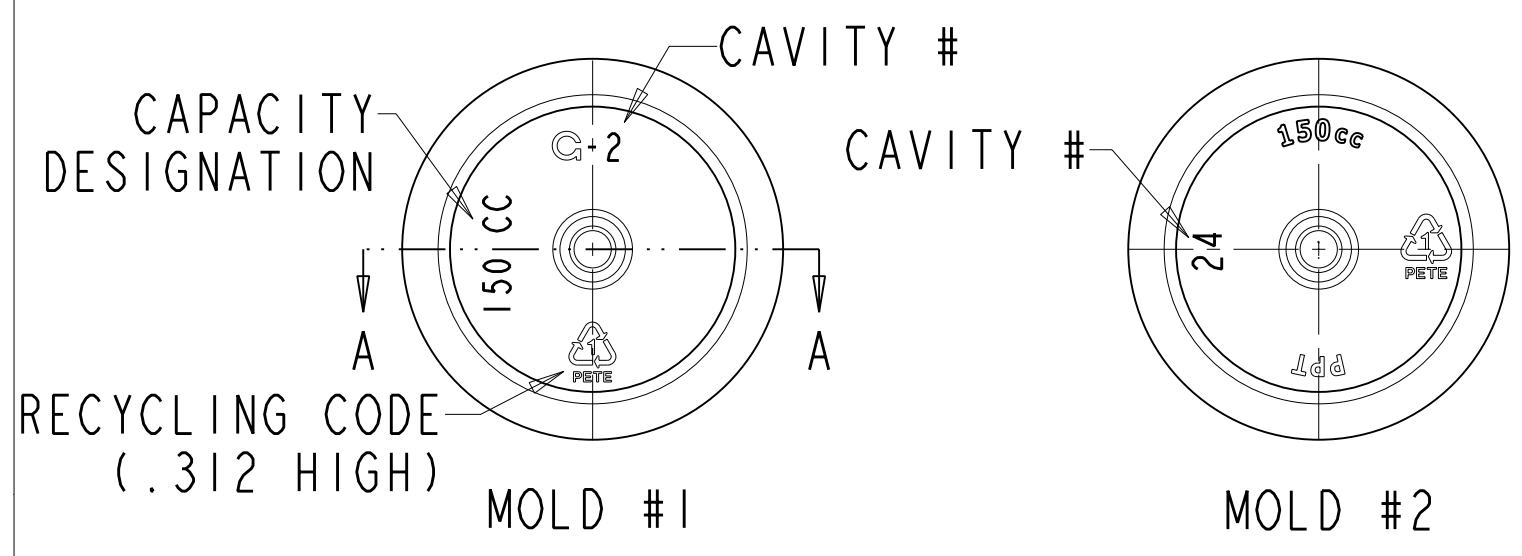

A1 NOTES:

- 1 - MOLD NO. 400113
- 2 - MAX. VARIATION IN AVERAGE DIAMETER BETWEEN TOP AND BOTTOM NOT TO EXCEED .010
- 3 - ALL DIMENSIONS APPLY AS MOLDED
- 4 - MAXIMUM OUT OF ROUNDNESS ON BODY OF CONTAINER NOT TO EXCEED .015.
- 5 - .012" MIN. WALL THICKNESS.

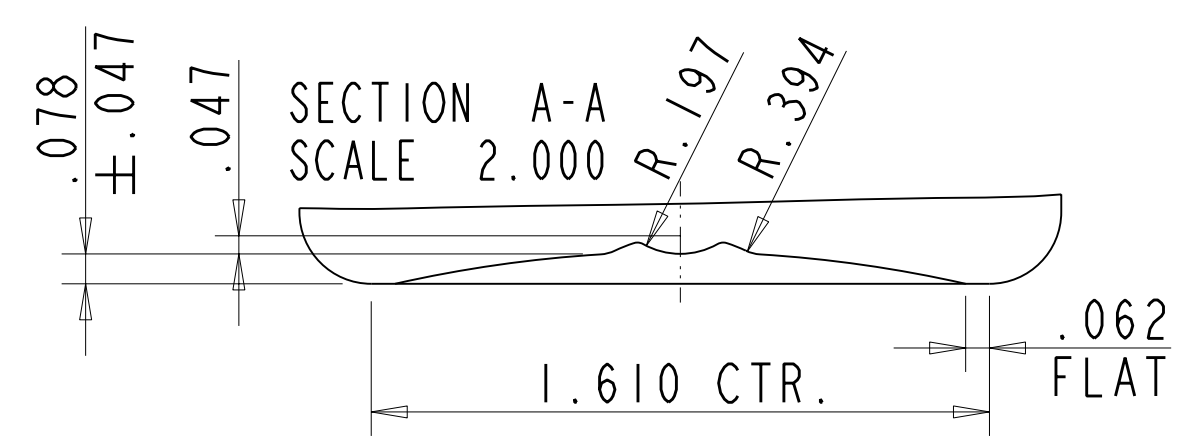
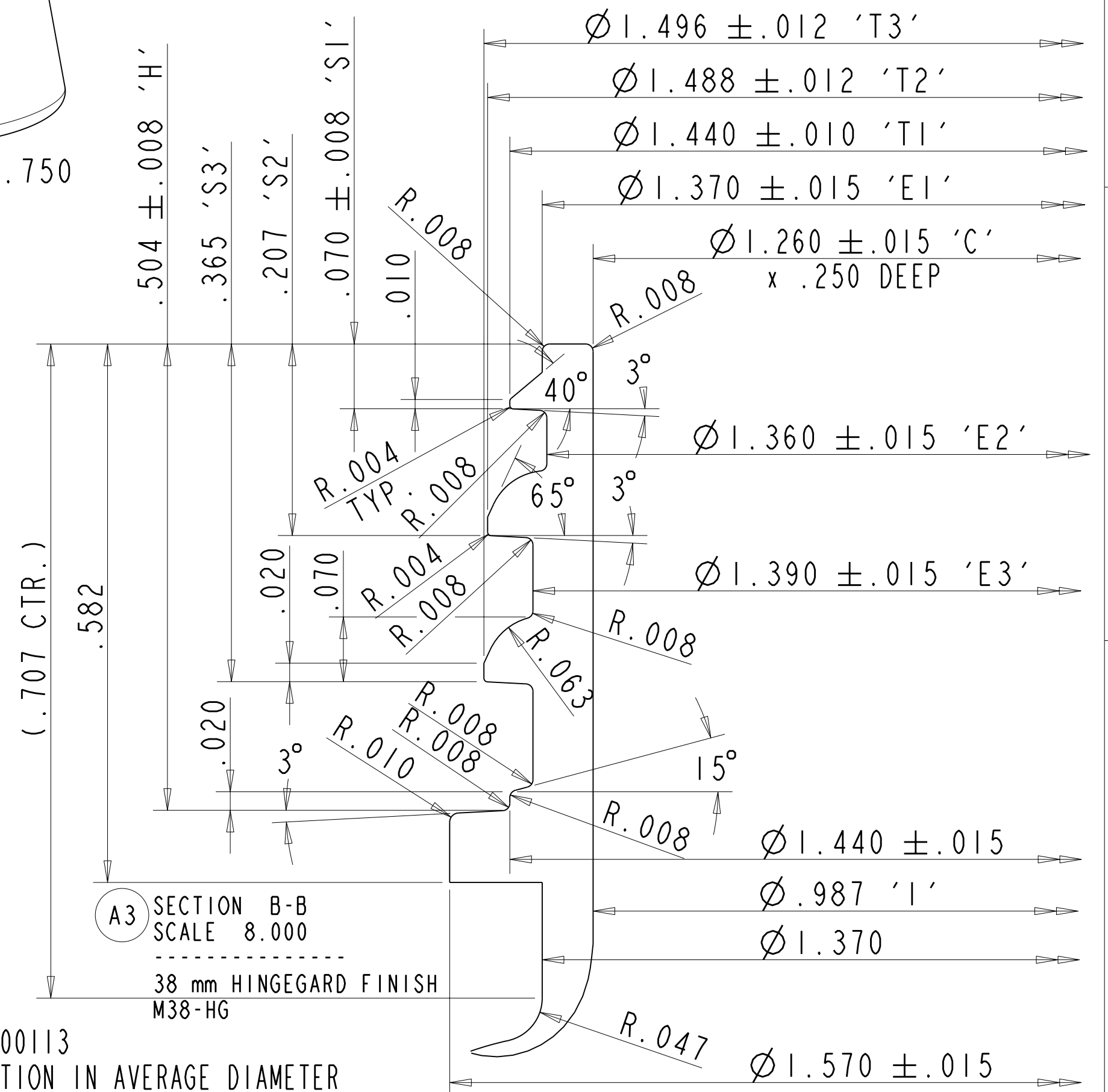

RESTRICTED, CONFIDENTIAL DOCUMENT

THIS DOCUMENT AND THE INFORMATION THEREON IS THE SOLE AND EXCLUSIVE PROPERTY OF PERFORMANCE PLASTIC TECHNOLOGIES AND/OR ITS DESIGNATED DISTRIBUTOR ABOVE. IT IS BEING ENTRUSTED TO RECIPIENT FOR A SPECIFIC LIMITED PURPOSE AND MAY BE USED ONLY FOR SUCH PURPOSE. BY ACCEPTING THIS DOCUMENT, THE RECIPIENT AGREES THAT HE WILL ENSURE THAT THE DOCUMENT AND ALL INFORMATION THEREON: (1) WILL BE MAINTAINED IN STRICTEST CONFIDENCE; (2) WILL NOT BE REPRODUCED, IN WHOLE OR IN PART, IN ANY MANNER WHATSOEVER WITHOUT THE EXPRESS WRITTEN APPROVAL OF PPT; (3) WILL NOT BE DISCLOSED DIRECTLY OR INDIRECTLY, IN ANY MANNER OR FORM, TO ANY THIRD PARTY WITHOUT THE EXPRESS WRITTEN APPROVAL OF PPT AND; (4) WILL BE PROMPTLY AND VOLUNTARILY RETURNED, WITH ANY AND ALL COPIES, TO PPT WHEN IT HAS SERVED THE PURPOSE INTENDED BY PPT, OR AT THE REQUEST OF PPT.



150 cc HG ROUND WIDE MOUTH PACKER
38 mm HINGEGARD FINISH

24.86 SQUARE INCHES	6.83 SQUARE INCHES	21.0 ±1.0	PET	170.0 ±5.0 cc (5.75 ±.17 fl oz)
SURFACE AREA BELOW BASE OF NECK	AREA AT PART LINE BELOW BASE OF NECK	GRAMS	MAT'L.	OVERFLOW CAPACITY

FILE NAME: XXXX_150cc-STR-SIDE (15-077-02-C)	SIZE DRAWN BY: C ES	DWG NO. 3165-0103-C
SCALE: 1,4:1	DATE: 10-07-2015	SHEET 1 OF 1