

REV	DATE	BY	REVISION
	092910	RRJ	THIS DRAWING WAS REDRAWN FROM GMP-1002-C-PD.
A	101810	RRJ	A1 REMOVED NOTES 5 & 6, A2 REMOVED DIM'S 1.994 & .997, A3 REVISED THREAD DETAIL.
B	101915	ES	REDRAWN FROM 3199-0103-A.
C	050917	ES	UPDATED PUSHUP ENGRAVING.
D	081518	ES	ADDED MIN. WALL LOCATION & NOTE 5.

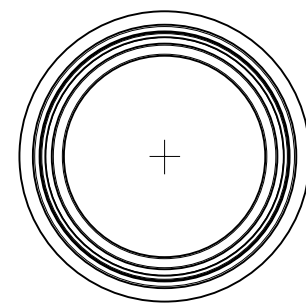

SCALE 0.750

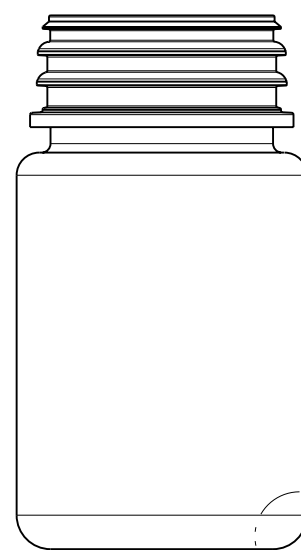
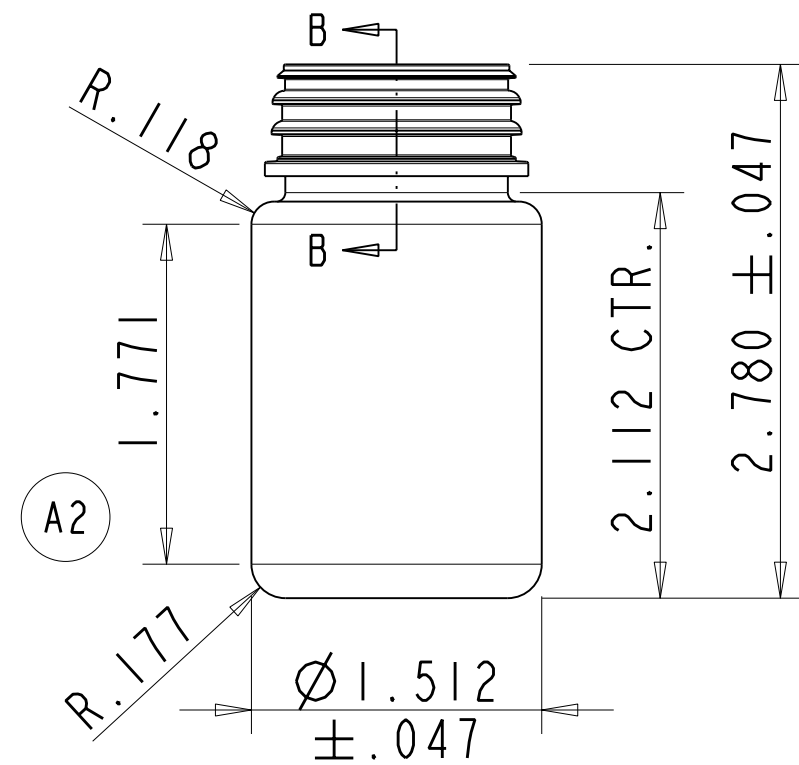

Ø .012" MIN. WALL

NOTE: THIS ITEM NEVER PRODUCED:
DIMENSIONS NEED TO BE VERIFIED.

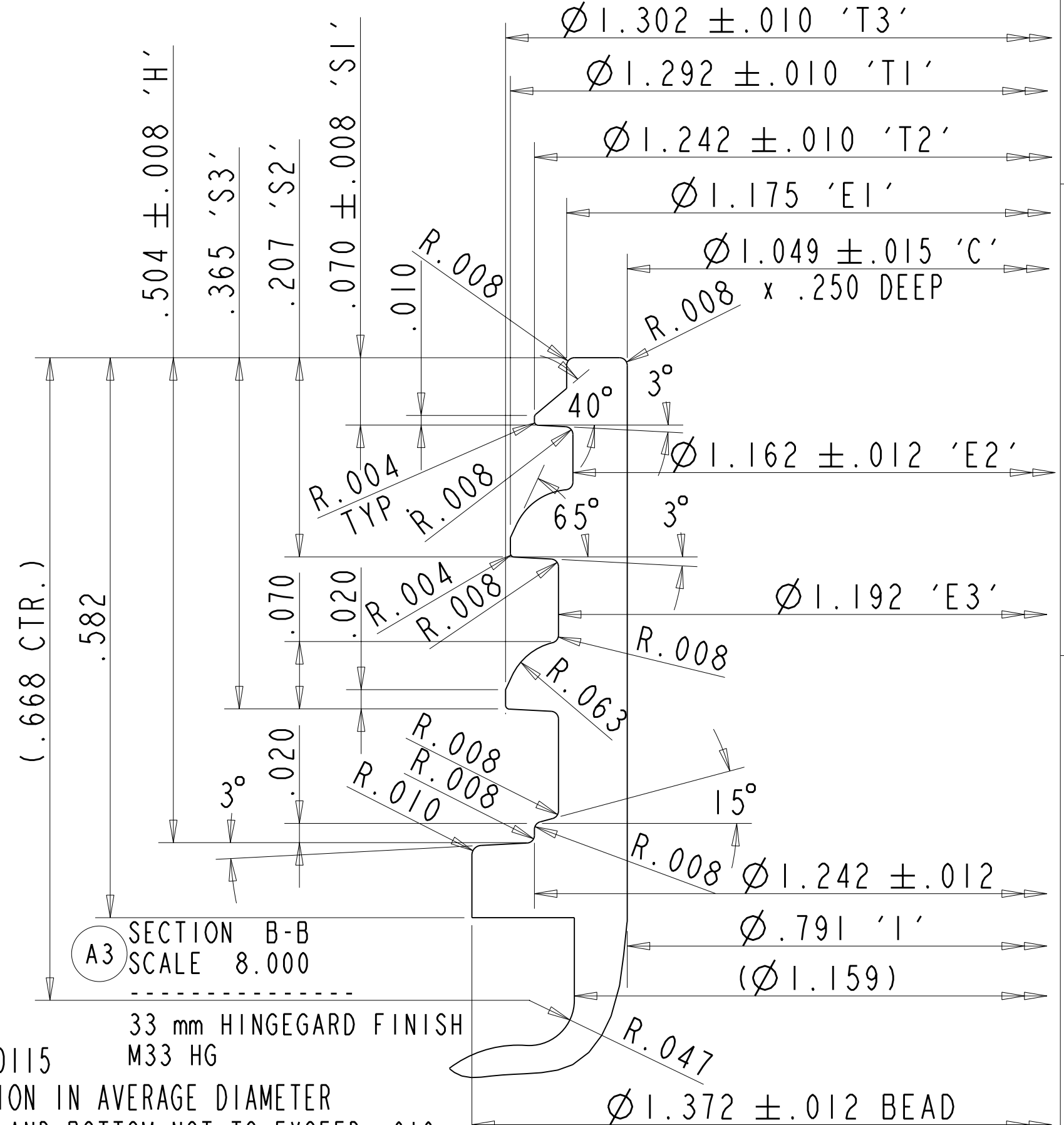
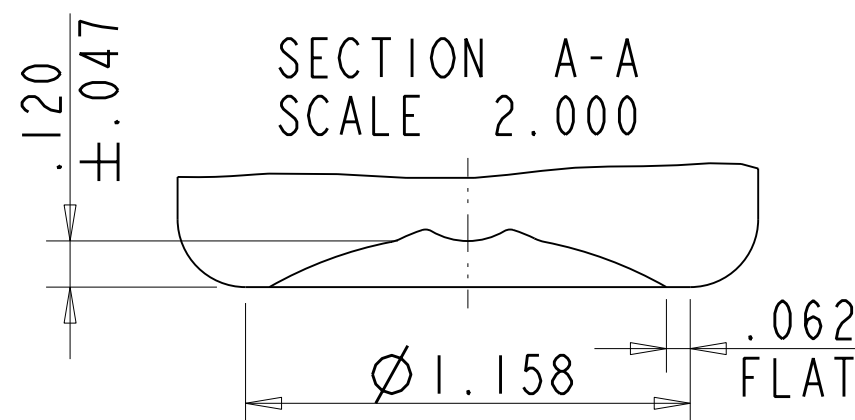
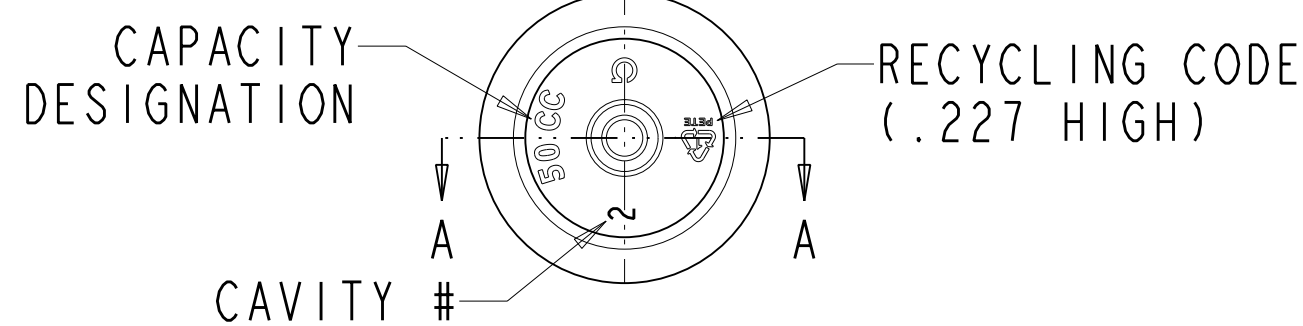

- (A1) NOTES:
- 1 - MOLD NO. 400115 M33 HG
 - 2 - MAX. VARIATION IN AVERAGE DIAMETER BETWEEN TOP AND BOTTOM NOT TO EXCEED .010
 - 3 - ALL DIMENSIONS APPLY AS MOLDED
 - 4 - MAXIMUM OUT OF ROUNDNESS ON BODY OF CONTAINER NOT TO EXCEED .015.
 - 5 - .012" MIN. WALL THICKNESS.

RESTRICTED, CONFIDENTIAL DOCUMENT

THIS DOCUMENT AND THE INFORMATION THEREON IS THE SOLE AND EXCLUSIVE PROPERTY OF PERFORMANCE PLASTIC TECHNOLOGIES AND/OR ITS DESIGNATED DISTRIBUTOR ABOVE. IT IS BEING ENTRUSTED TO RECIPIENT FOR A SPECIFIC LIMITED PURPOSE AND MAY BE USED ONLY FOR SUCH PURPOSE. BY ACCEPTING THIS DOCUMENT, THE RECIPIENT AGREES THAT HE WILL ENSURE THAT THE DOCUMENT AND ALL INFORMATION THEREON: (1) WILL BE MAINTAINED IN STRICTEST CONFIDENCE; (2) WILL NOT BE REPRODUCED, IN WHOLE OR IN PART, IN ANY MANNER WHATSOEVER WITHOUT THE EXPRESS WRITTEN APPROVAL OF PPT; (3) WILL NOT BE DISCLOSED DIRECTLY OR INDIRECTLY, IN ANY MANNER OR FORM, TO ANY THIRD PARTY WITHOUT THE EXPRESS WRITTEN APPROVAL OF PPT AND; (4) WILL BE PROMPTLY AND VOLUNTARILY RETURNED, WITH ANY AND ALL COPIES, TO PPT WHEN IT HAS SERVED THE PURPOSE INTENDED BY PPT, OR AT THE REQUEST OF PPT.



50 cc HG ROUND WIDE MOUTH PACKER
33 mm HINGEGARD FINISH

FILE NAME:
XXXX_50cc-STR-SIDE
(15-082-02-D)

SIZE DRAWN BY: C RRJ DWG NO. 3199-0103-D
SCALE: 1,4:1 DATE: 09-29-2010 SHEET 1 OF 1

12.4 SQUARE INCHES	3.32 SQUARE INCHES	11.0 ± .8	PET	64.8 ± 2.5 cc (2.19 ± .08 fl oz)
SURFACE AREA BELOW BASE OF NECK	AREA AT PART LINE BELOW BASE OF NECK	GRAMS	MAT'L.	OVERFLOW CAPACITY