

| REV | DATE   | BY  | REVISION   |
|-----|--------|-----|--|
| A   | 092810 | RRJ | REMOVED NOTES 5 & 6,<br>A2 REMOVED DIM'S 2.081 & 1.095,<br>A3 REVISED THREAD DETAIL. |
| B   | 100215 | ES  | REDRAWN FROM 3198-0203-A.  |
| C   | 050917 | ES  | UPDATED PUSHUP ENGRAVING.  |
| D   | 081518 | ES  | ADDED MIN.WALL LOCATION & NOTE 5.  |
|     |        |     |  |
|     |        |     |  |

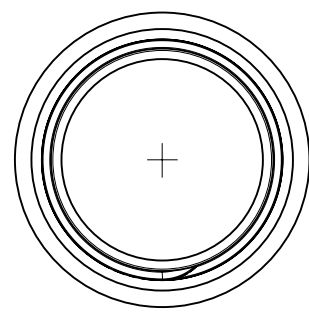

SCALE 0.750

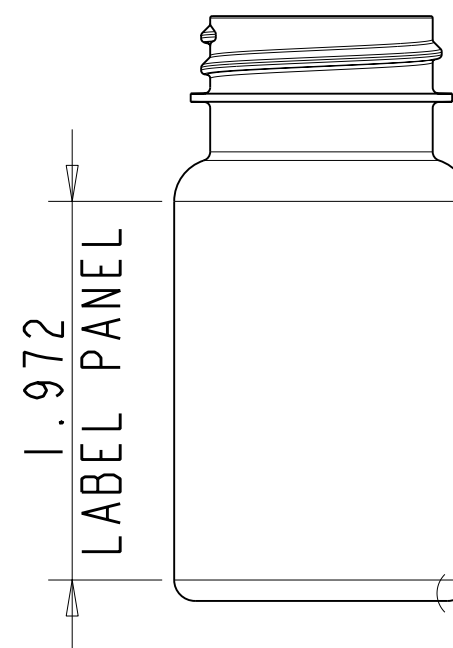
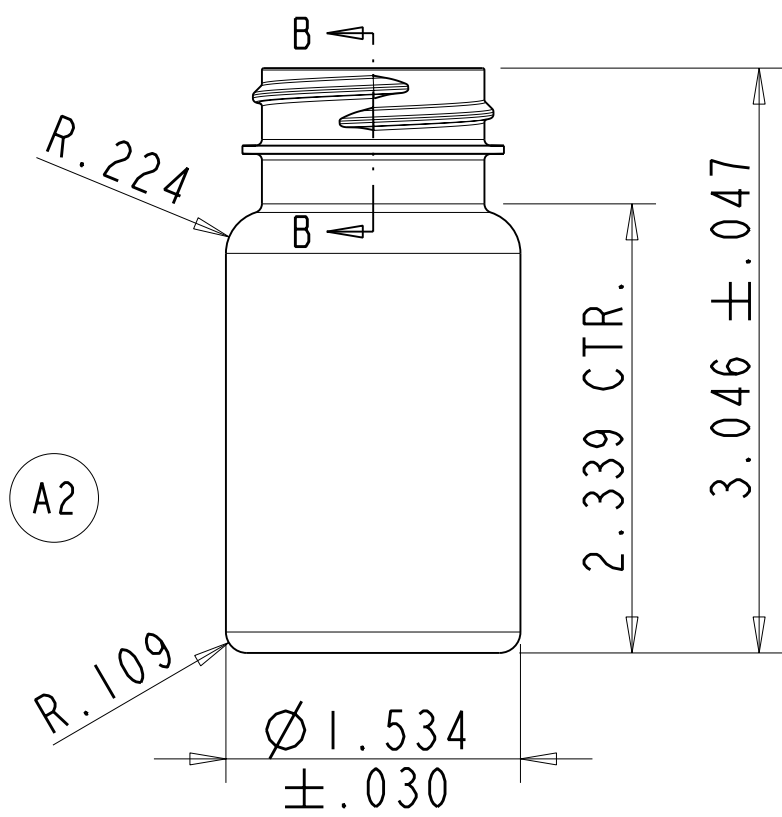

Ø .012" MIN. WALL

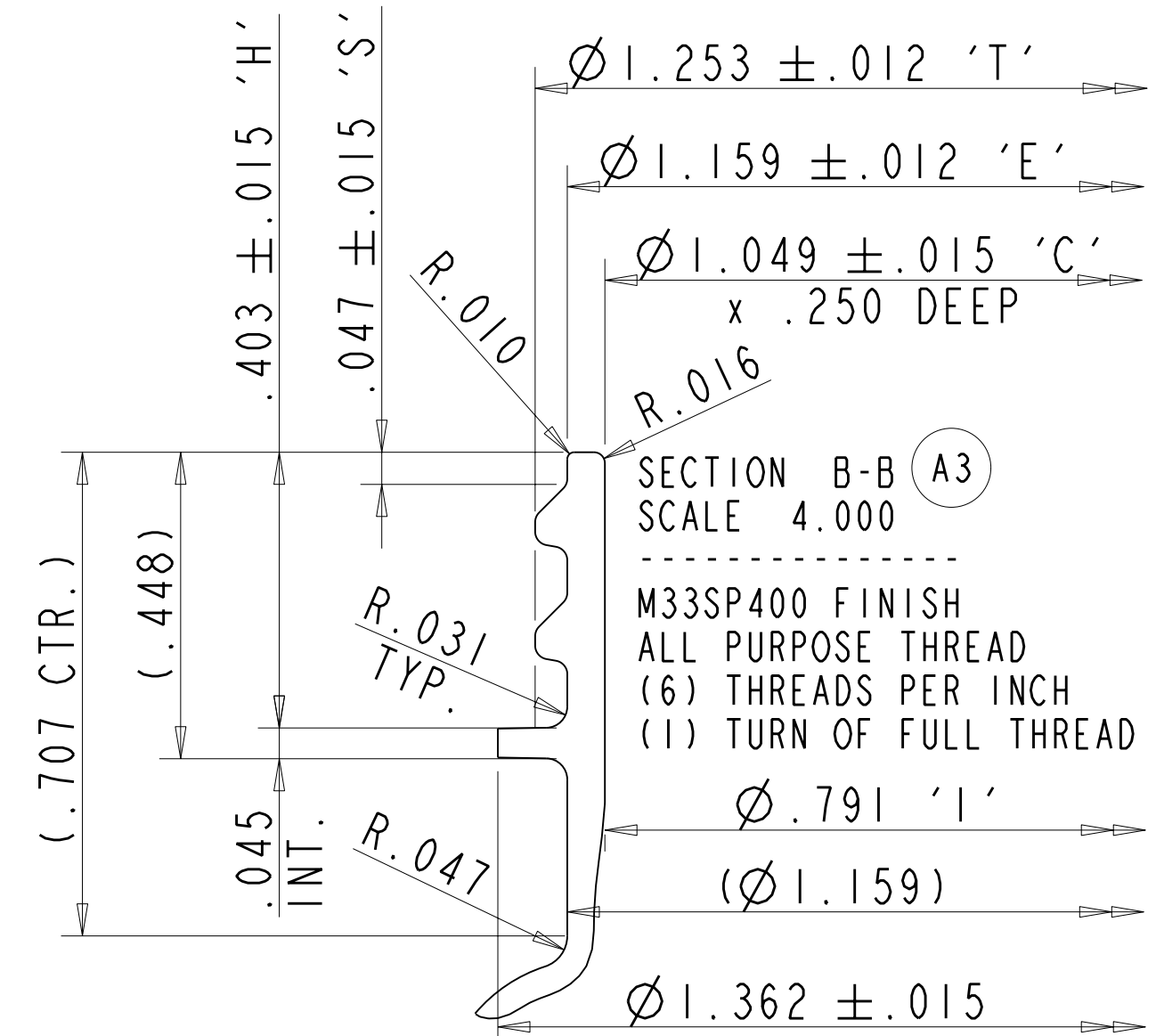

SECTION B-B (A3)  
SCALE 4.000

M33SP400 FINISH  
ALL PURPOSE THREAD  
(6) THREADS PER INCH  
(1) TURN OF FULL THREAD

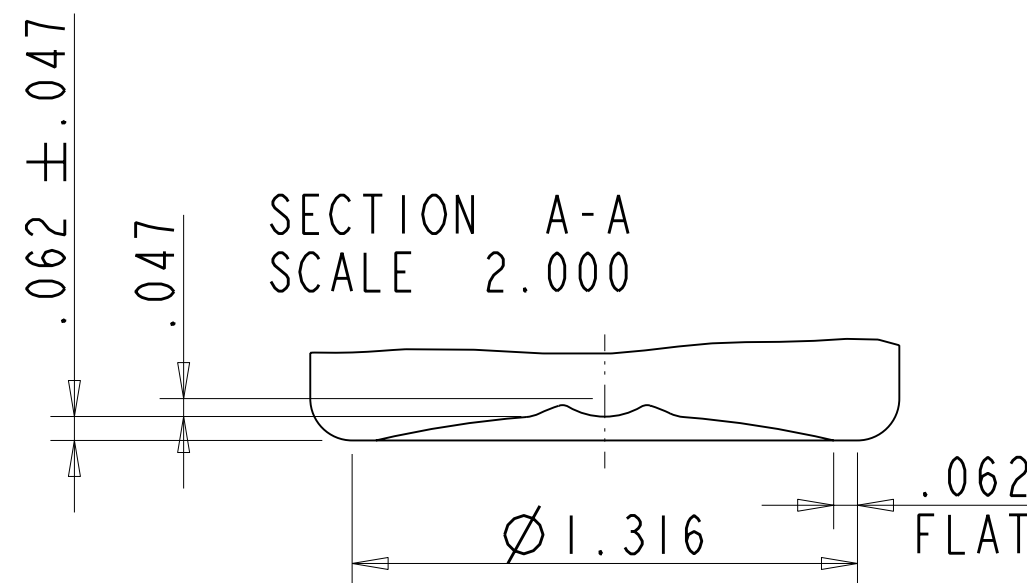

SECTION A-A  
SCALE 2.000

(A1) NOTES:

- 1 - MOLD NO. NB-400116
- 2 - MAX. VARIATION IN AVERAGE DIAMETER BETWEEN TOP AND BOTTOM NOT TO EXCEED .010
- 3 - ALL DIMENSIONS APPLY AS MOLDED
- 4 - MAXIMUM OUT OF ROUNDNESS ON BODY OF CONTAINER NOT TO EXCEED .015.
- 5 - .012" MIN. WALL THICKNESS.

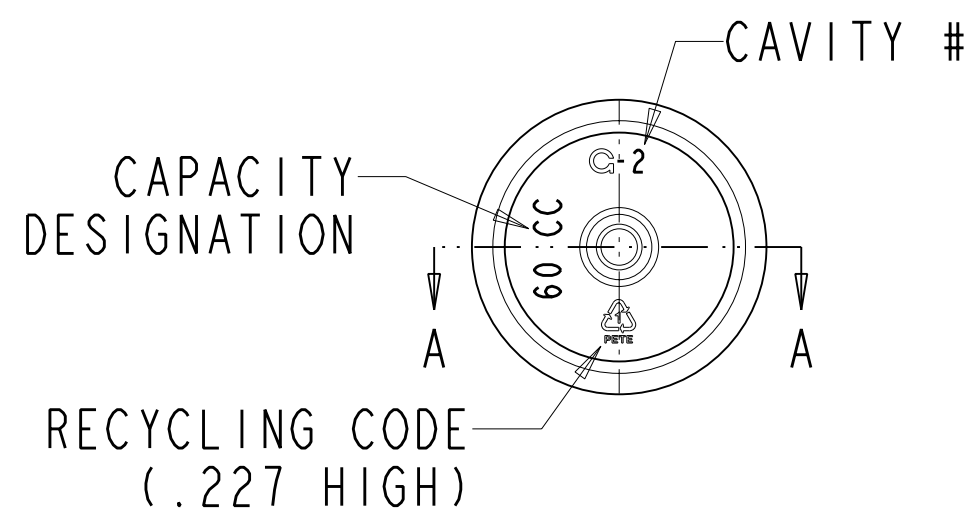

RESTRICTED, CONFIDENTIAL DOCUMENT

THIS DOCUMENT AND THE INFORMATION THEREON IS THE SOLE AND EXCLUSIVE PROPERTY OF PERFORMANCE PLASTIC TECHNOLOGIES AND/OR ITS DESIGNATED DISTRIBUTOR ABOVE. IT IS BEING ENTRUSTED TO RECIPIENT FOR A SPECIFIC LIMITED PURPOSE AND MAY BE USED ONLY FOR SUCH PURPOSE. BY ACCEPTING THIS DOCUMENT, THE RECIPIENT AGREES THAT HE WILL ENSURE THAT THE DOCUMENT AND ALL INFORMATION THEREON: (1) WILL BE MAINTAINED IN STRICTEST CONFIDENCE; (2) WILL NOT BE REPRODUCED, IN WHOLE OR IN PART, IN ANY MANNER WHATSOEVER WITHOUT THE EXPRESS WRITTEN APPROVAL OF PPT; (3) WILL NOT BE DISCLOSED DIRECTLY OR INDIRECTLY, IN ANY MANNER OR FORM, TO ANY THIRD PARTY WITHOUT THE EXPRESS WRITTEN APPROVAL OF PPT AND; (4) WILL BE PROMPTLY AND VOLUNTARILY RETURNED, WITH ANY AND ALL COPIES, TO PPT WHEN IT HAS SERVED THE PURPOSE INTENDED BY PPT, OR AT THE REQUEST OF PPT.



60 cc CT ROUND WIDE MOUTH PACKER  
M33SP400 FINISH

FILE NAME:  
XXXX\_60cc-STR-SIDE  
(15-083-01-D)

SIZE C DRAWN BY: RRJ DWG NO. 3198-0203-D  
SCALE: 1,4:1 DATE: 08-28-2010 SHEET 1 OF 1

|                                 |                                      |           |        |                                |
|---------------------------------|--------------------------------------|-----------|--------|--------------------------------|
| 13.8 SQUARE INCHES              | 3.74 SQUARE INCHES                   | 10.0 ±1.0 | PET    | 74.7 ±3.0 cc (2.53 ±.10 fl oz) |
| SURFACE AREA BELOW BASE OF NECK | AREA AT PART LINE BELOW BASE OF NECK | GRAMS     | MAT'L. | OVERFLOW CAPACITY              |