

REV	DATE	BY	REVISION
	091710	RRJ	THIS DRAWING HAS BEEN REDRWN FROM GMP-1010-C-PD.
A	091710	RRJ	A1 REMOVED NOTES 5 & 6, A2 REMOVED DIM'S 2.412 & 1.284, A3 REVISED NECK DETAIL.
B	101915	ES	REDRAWN FROM 3196-0103-A.

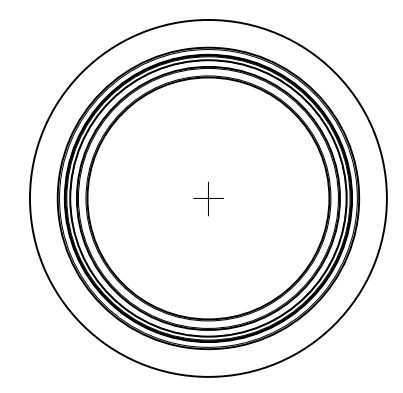

SCALE 0.750

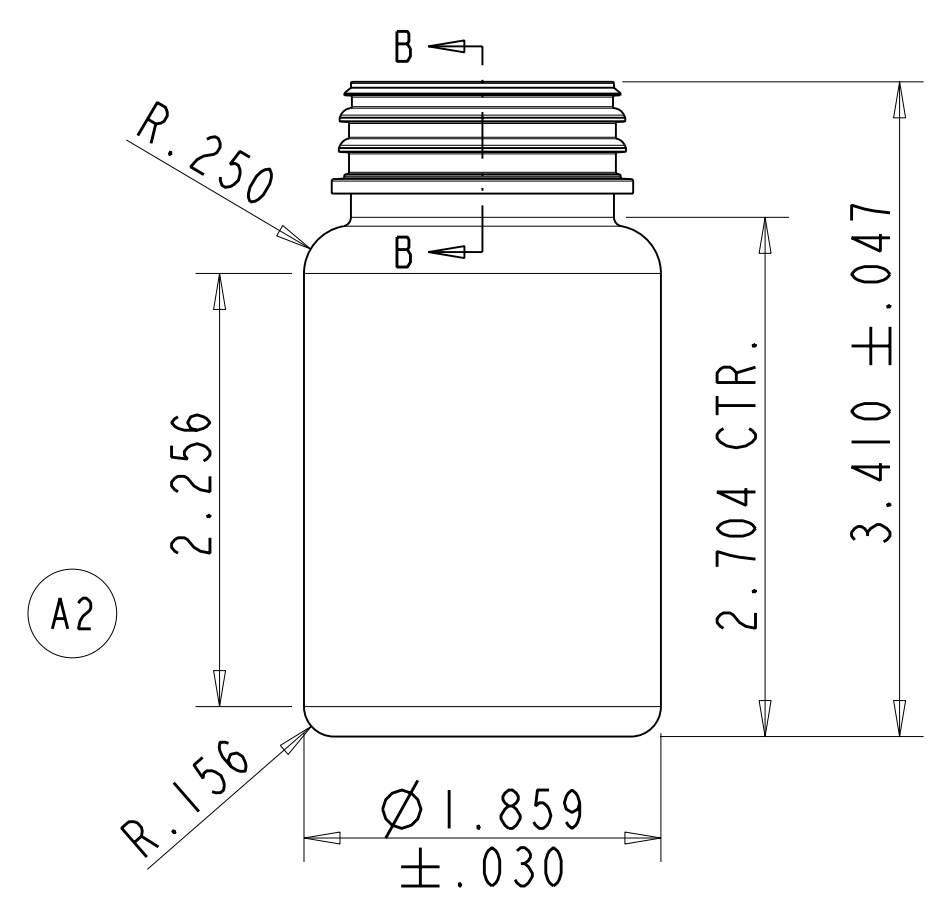

A2

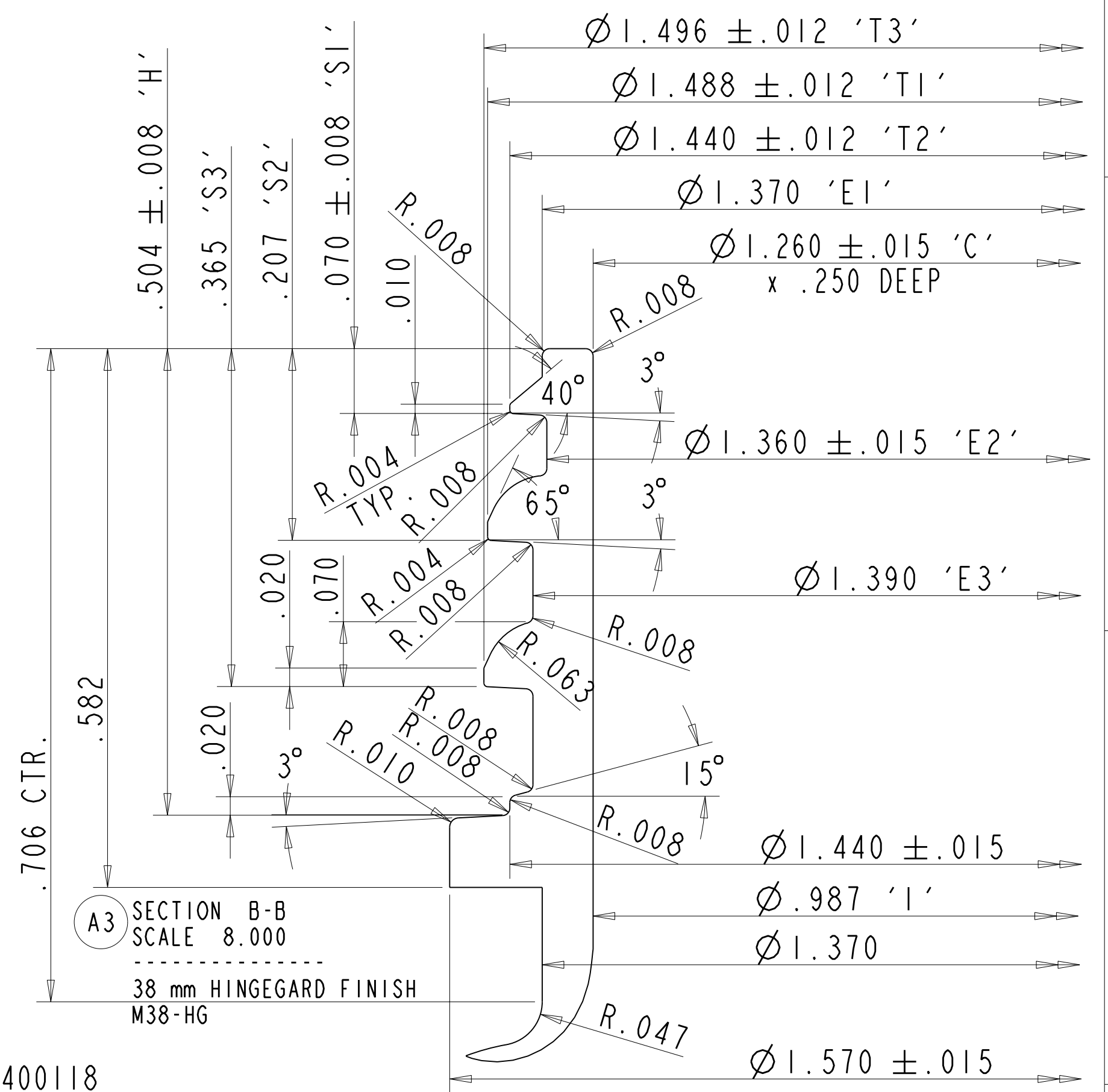
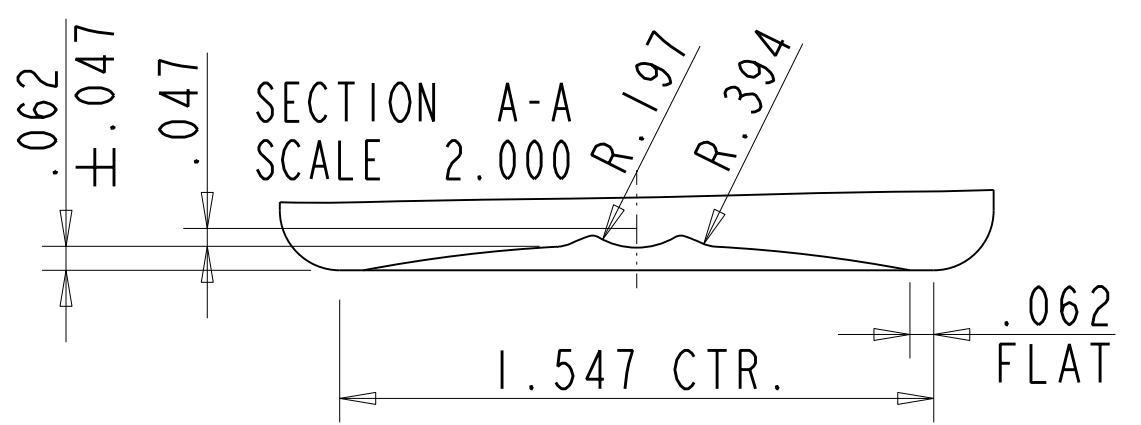
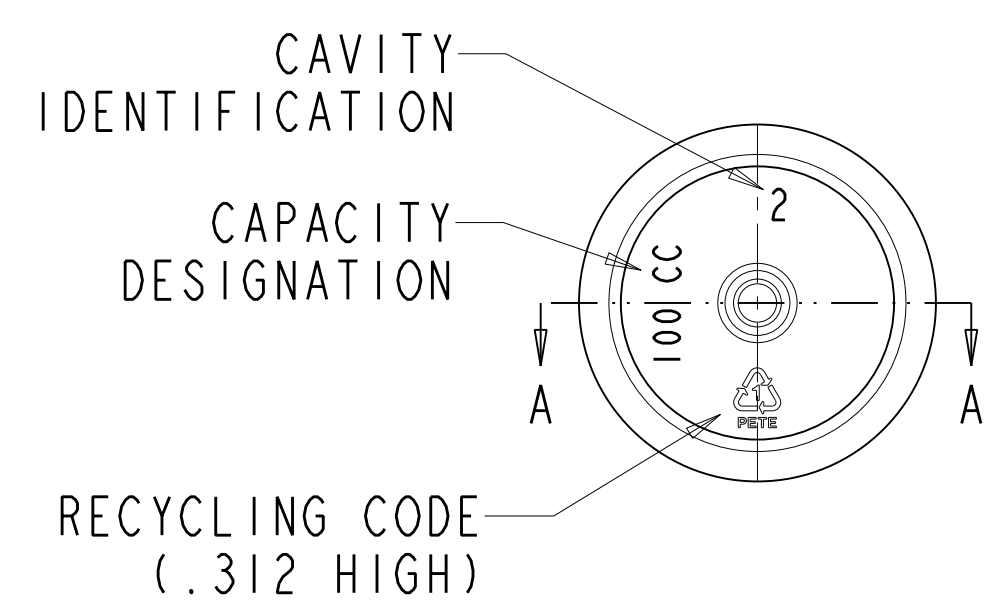

A3 SECTION B-B
SCALE 8.000
38 mm HINGEGARD FINISH
M38-HG

- A1 NOTES:
- 1 - MOLD NO. 400118
 - 2 - MAX. VARIATION IN AVERAGE DIAMETER BETWEEN TOP AND BOTTOM NOT TO EXCEED .010
 - 3 - ALL DIMENSIONS APPLY AS MOLDED
 - 4 - MAXIMUM OUT OF ROUNDNESS ON BODY OF CONTAINER NOT TO EXCEED .015

RESTRICTED, CONFIDENTIAL DOCUMENT

THIS DOCUMENT AND THE INFORMATION THEREON IS THE SOLE AND EXCLUSIVE PROPERTY OF PERFORMANCE PLASTIC TECHNOLOGIES AND/OR ITS DESIGNATED DISTRIBUTOR ABOVE. IT IS BEING ENTRUSTED TO RECIPIENT FOR A SPECIFIC LIMITED PURPOSE AND MAY BE USED ONLY FOR SUCH PURPOSE. BY ACCEPTING THIS DOCUMENT, THE RECIPIENT AGREES THAT HE WILL ENSURE THAT THE DOCUMENT AND ALL INFORMATION THEREON: (1) WILL BE MAINTAINED IN STRICTEST CONFIDENCE; (2) WILL NOT BE REPRODUCED, IN WHOLE OR IN PART, IN ANY MANNER WHATSOEVER WITHOUT THE EXPRESS WRITTEN APPROVAL OF PPT; (3) WILL NOT BE DISCLOSED DIRECTLY OR INDIRECTLY, IN ANY MANNER OR FORM, TO ANY THIRD PARTY WITHOUT THE EXPRESS WRITTEN APPROVAL OF PPT AND; (4) WILL BE PROMPTLY AND VOLUNTARILY RETURNED, WITH ANY AND ALL COPIES, TO PPT WHEN IT HAS SERVED THE PURPOSE INTENDED BY PPT, OR AT THE REQUEST OF PPT.



100 cc HG ROUND WIDE MOUTH PACKER
38 mm HINGEGARD FINISH

FILE NAME: XXXX_100 cc-STR-SIDE (15-075-02-B)
SIZE C DRAWN BY: RRJ DWG NO. 3196-0103-B
SCALE: 1,4:1 DATE: 09-17-2010 SHEET 1 OF 1

19.29 SQUARE INCHES	5.19 SQUARE INCHES	15.0 ±1.0	PET	123.9 ±4.5 cc (4.19 ±.15 fl oz)
SURFACE AREA BELOW BASE OF NECK	AREA AT PART LINE BELOW BASE OF NECK	GRAMS	MAT'L.	OVERFLOW CAPACITY