

REV	DATE	BY	REVISION
	082510	RRJ	THIS DRAWING HAS BEEN REDRAWN FROM GMP-1012-C-PD.
A	091610	RRJ	REVISED TITLE BLOCK AND NOTES
B	101510	RRJ	B1 REMOVED NOTES 5 & 6, B2 REMOVED DIM'S 2.528 & 1.342, B3 REVISED NECK DETAIL.
C	102810	RRJ	REVISED NECK FINISH DESIGNATION.
D	101915	ES	REDRAWN FROM 3167-0103C.

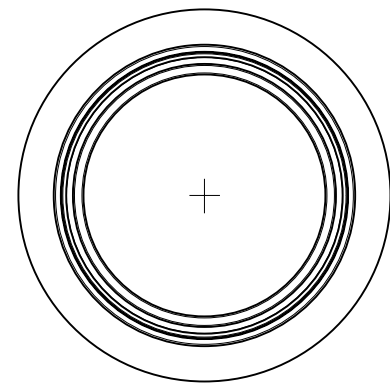

SCALE 0.750

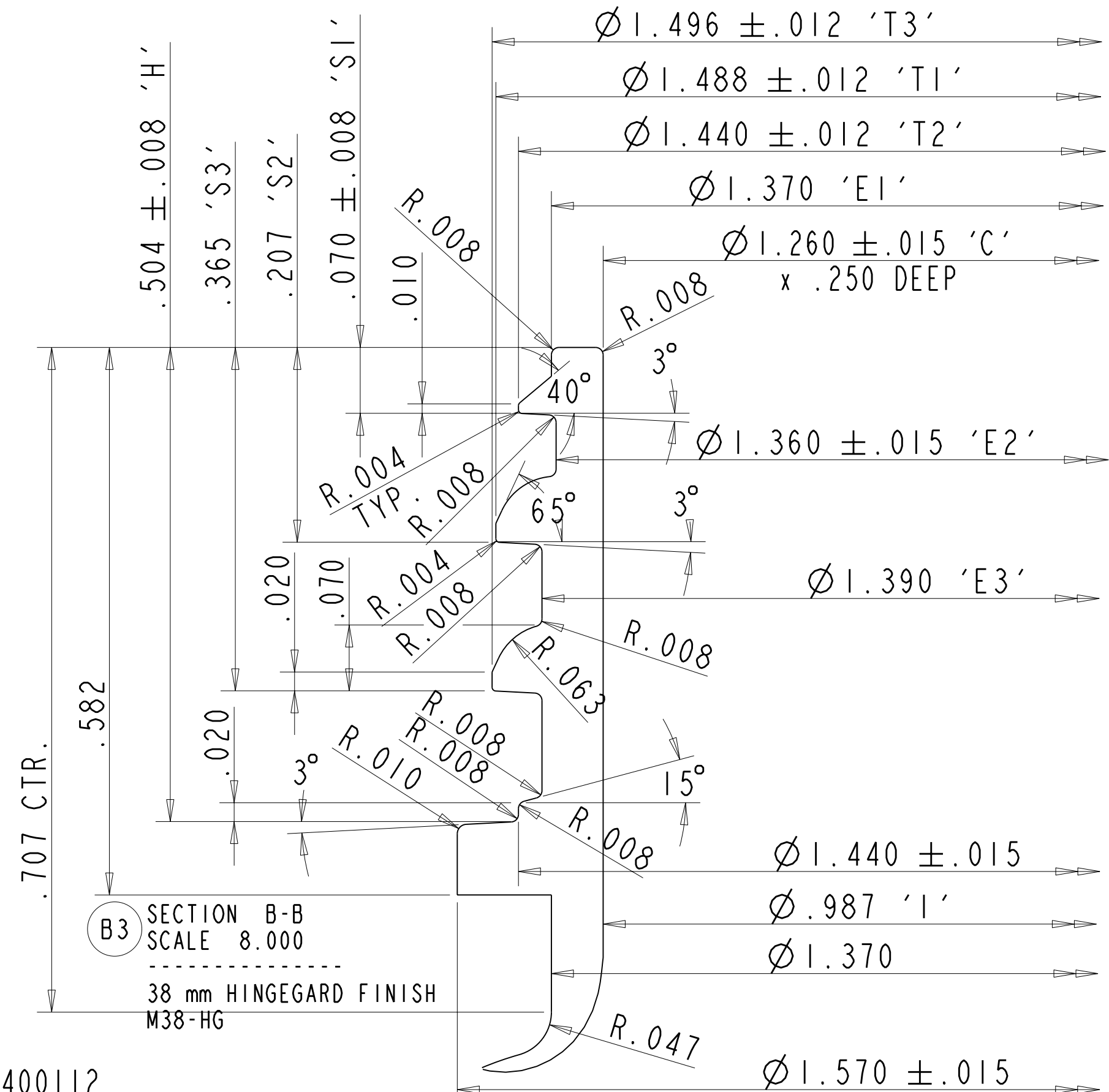
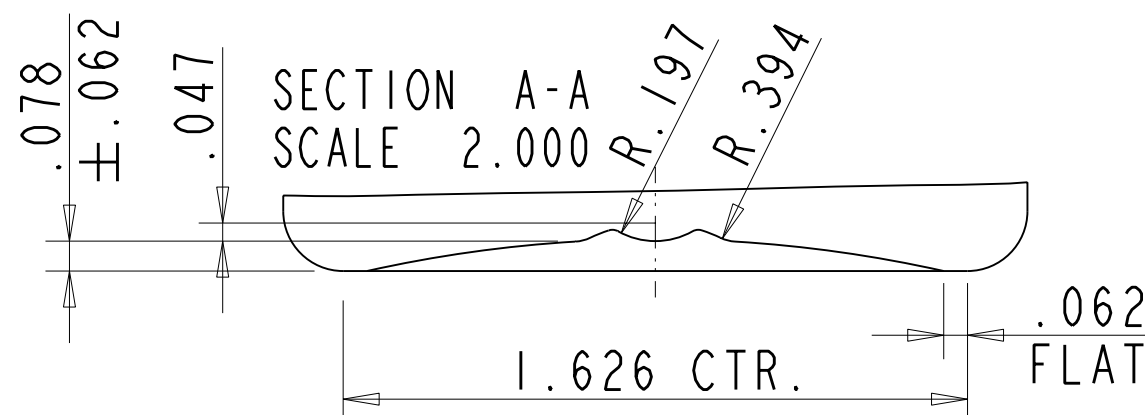
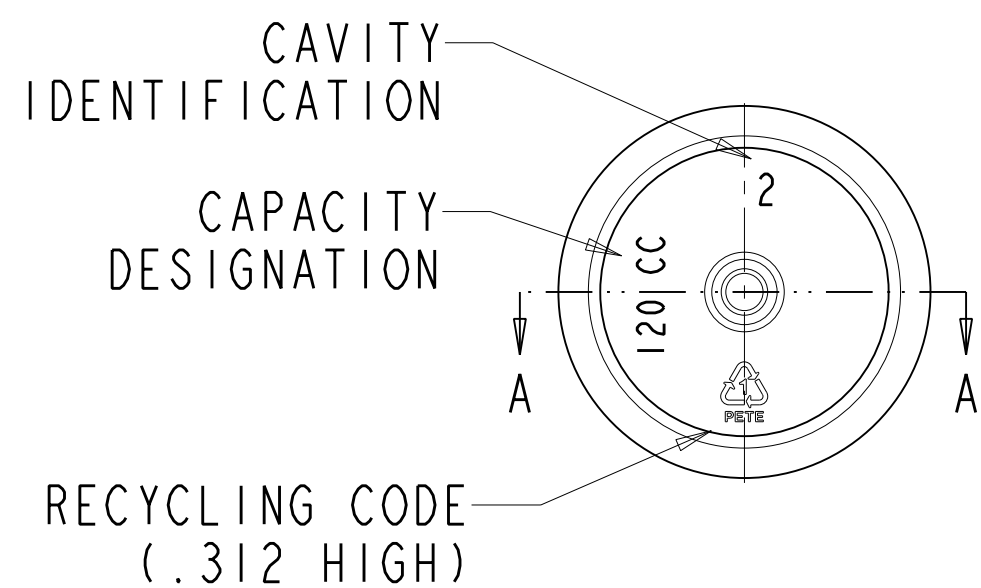
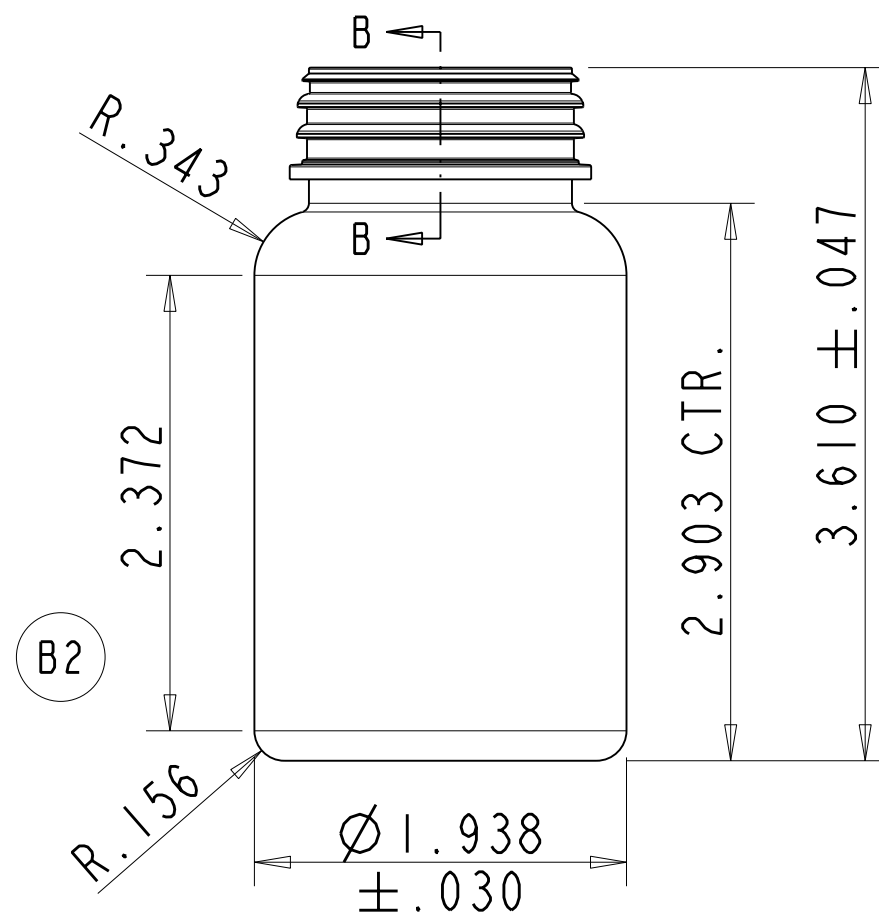

- (B1) NOTES:
- 1 - MOLD NO. 400112
 - 2 - MAX. VARIATION IN AVERAGE DIAMETER BETWEEN TOP AND BOTTOM NOT TO EXCEED .010
 - 3 - ALL DIMENSIONS APPLY AS MOLDED
 - 4 - MAXIMUM OUT OF ROUNDNESS ON BODY OF CONTAINER NOT TO EXCEED .015

RESTRICTED, CONFIDENTIAL DOCUMENT

THIS DOCUMENT AND THE INFORMATION THEREON IS THE SOLE AND EXCLUSIVE PROPERTY OF PERFORMANCE PLASTIC TECHNOLOGIES AND/OR ITS DESIGNATED DISTRIBUTOR ABOVE. IT IS BEING ENTRUSTED TO RECIPIENT FOR A SPECIFIC LIMITED PURPOSE AND MAY BE USED ONLY FOR SUCH PURPOSE. BY ACCEPTING THIS DOCUMENT, THE RECIPIENT AGREES THAT HE WILL ENSURE THAT THE DOCUMENT AND ALL INFORMATION THEREON: (1) WILL BE MAINTAINED IN STRICTEST CONFIDENCE; (2) WILL NOT BE REPRODUCED, IN WHOLE OR IN PART, IN ANY MANNER WHATSOEVER WITHOUT THE EXPRESS WRITTEN APPROVAL OF PPT; (3) WILL NOT BE DISCLOSED DIRECTLY OR INDIRECTLY, IN ANY MANNER OR FORM, TO ANY THIRD PARTY WITHOUT THE EXPRESS WRITTEN APPROVAL OF PPT AND; (4) WILL BE PROMPTLY AND VOLUNTARILY RETURNED, WITH ANY AND ALL COPIES, TO PPT WHEN IT HAS SERVED THE PURPOSE INTENDED BY PPT, OR AT THE REQUEST OF PPT.



120 cc HG ROUND WIDE MOUTH PACKER
38 mm HINGEGARD FINISH

20.03 SQUARE INCHES	5.49 SQUARE INCHES	17.0 ±1.0	PET	141.4 ±4.5 cc (4.78 ±.15 fl oz)
SURFACE AREA BELOW BASE OF NECK	AREA AT PART LINE BELOW BASE OF NECK	GRAMS	MAT'L.	OVERFLOW CAPACITY

FILE NAME: XXXX_120 cc-STR-SIDE (15-076-02-D)	SIZE DRAWN BY: C RRJ	DWG NO. 3167-0103-D
SCALE: 1,4:1	DATE: 08-25-2010	SHEET 1 OF 1